

## 5.2 cu. ft. Front Load Washer

- 5.2 cu.ft. Mega Capacity
- TurboWash® Technology
- 14 Cycles / 11 Options
- Allergiene™ Cycle
- ColdWash™ Option
- Direct Drive Motor (10-Year Limited Warranty)
- NeveRust™ Stainless Steel Tub
- Drum Light
- SmartDiagnosis™



### COLOR AVAILABILITY

- WM8100HVA – Graphite Steel

### CAPACITY & MATCHING DRYERS

Capacity (cu. ft.)	5.2
Matching Electric Dryer	DLEX8100V
Matching Gas Dryer	DLGX8101V

### APPEARANCE

Electronic Controls with LED Display	Yes
Hard Buttons	Yes
Touch Buttons	Yes
Dial-A-Cycle™	Yes

### ENERGY & WATER

ENERGY STAR® Qualified	Yes
CEE Qualified	Tier 2
Integrated Modified Energy Factor (IMEF)	2.92
Integrated Water Factor (IWF)	3.2

### WASH CYCLES

Number of Cycles	14
Wash Cycles	Normal, Perm. Press, Heavy Duty, Delicates, Towels, Speed Wash, Hand Wash / Wool, Bulky / Large, Tub Clean, Bright White, Sanitary, Allergiene™, Jumbowash, Small Load

### WASH OPTIONS

Number of Options	11
Options	TurboWash®, Steam, Fresh Care, Prewash, Delay Wash, Extra Rinse, ColdWash™, Child Lock*, Rinse+Spin, Drum Light, Add Garments

### WASH DETAILS

Internal Heater	Yes
Number of Wash/Rinse Temps	5
Wash/Rinse Temps	Extra Hot, Hot, Warm, Cold, Tap Cold
Number of Spin Speeds	5
Spin Speeds	Extra High, High, Medium, Low, No Spin
Max RPM	1,300
Water Levels	Load Sensing
Number of Soil Levels	5
AAFA Certified	Yes

### FABRIC CARE

AI DD™	No
Wash Technology	TurboWash® 2.0
Steam Technology	Yes
Allergiene™ Cycle	Yes
Sanitary Cycle	Yes
ColdWash™ Option	Yes
SenseClean™ System	Yes

### CONVENIENCE

TrueBalance™ Anti-Vibration System	Yes
Dispenser Type	4-Tray (Prewash, Main Wash with Liquid Detergent Cup, Bleach, Fabric Softener)
LoDecibel™ Quiet Operation	Yes
End of Cycle Signal	Yes
LoadSense	Yes
Child Lock	Yes
Auto Suds Removal	Yes
4 Adjustable Leveling Legs	Yes
Easy Loading TiITub™	Yes
ADA Compliant	No

## SMART FEATURES

Wi-Fi Enabled	No
ThinQ®	No
SmartDiagnosis™	Yes

## MOTOR AND AGITATOR

Motor Type	Inverter Direct Drive Motor
Axis	Horizontal

## MATERIALS AND FINISHES

NeveRust™ Stainless Steel Drum	Yes
Door / Rim	Glass / Chrome
Door Cover	Dark Black Tinted Square Cover

## TECHNICAL SPECS

Electrical Requirements	120V, 60 Hz, 10 Amps
Type	Electric
Power Outlet Location	Within 60" of Either Side
Plug Type	3-Prong (Cord Attached to Unit)
Min. / Max. Water Pressure	20 - 120 psi

## INCLUDED ACCESSORIES

Drain Hose, Hot/Cold Water Hoses, Non-Skid Pads, Hole Caps, Wrench, Tie Strap, Elbow Bracket (for Securing Drain Hose)

## OPTIONAL ACCESSORIES

Pedestal	WDP5V
Pedestal (W x H x D)	29" x 13 5/8" x 29 1/2"
LG Sidekick™ Pedestal Washer	WD200CV
LG Sidekick™ Pedestal Washer (W x H x D)	29" x 14 1/8" x 30 7/8"
Stacking Kit	KSTK2

## DIMENSIONS

Product (W x H x D)	29" x 40 3/4" x 33"
Depth with Door Open	57 1/2"
Carton Dimensions (W x H x D)	31 3/8" x 44 3/4" x 33 3/4"
Approx. Weight (Product / Carton)	225 lbs. / 251.5 lbs.

## LIMITED WARRANTY

Parts and Labor	1 Year
Direct Drive Motor	10 Years (Parts Only)
Drum	Lifetime (Parts Only)

## DIMENSIONS / CLEARANCES

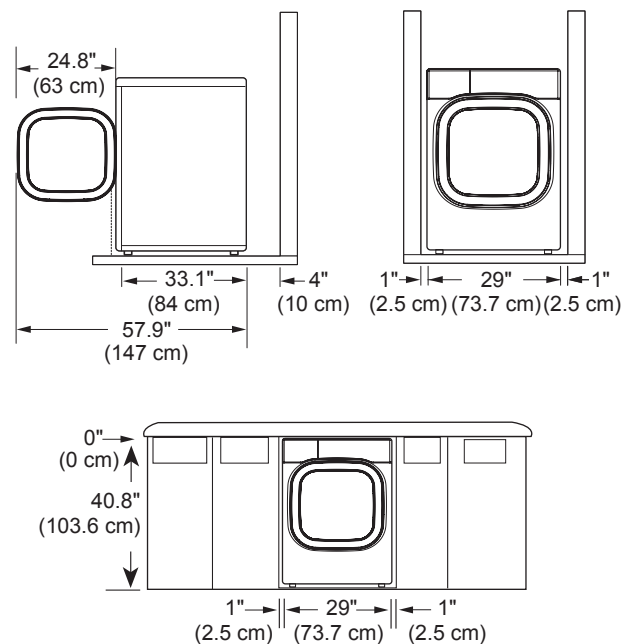

## INSTALLATION NOTES

- Allow sufficient space for water lines, the drain line, and airflow.
- Install the washing machine on a solid floor that is strong and rigid enough to support the weight of the washing machine, even when fully loaded, without flexing or bouncing. If the floor has too much flex, you may need to reinforce it to make it more rigid. If the floor is not solid, it may cause severe vibration and noise.
- If installing with an optional pedestal or SideKick™, refer to the instructions packaged with pedestals for dimensions and clearances.

ASTHMA & ALLERGY FRIENDLY Mark is a Registered Trade Mark of the ASTHMA AND ALLERGY FOUNDATION OF AMERICA and ALLERGY STANDARDS LTD.